

Tolérance générale: Js12

Echelle 1:1

Couvercle de batterie

Dossier technique

Document DT1

Page 6/23

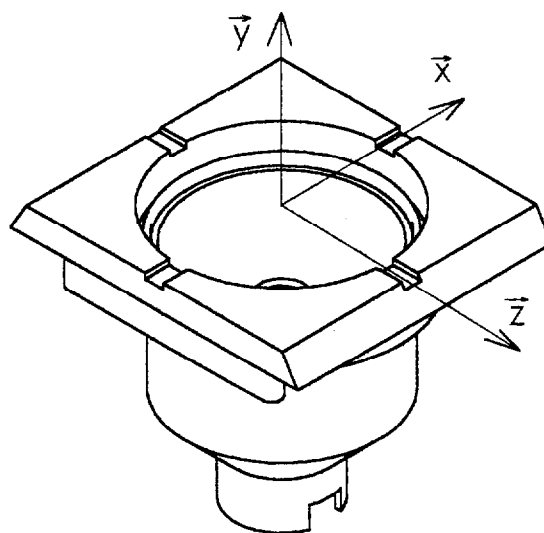
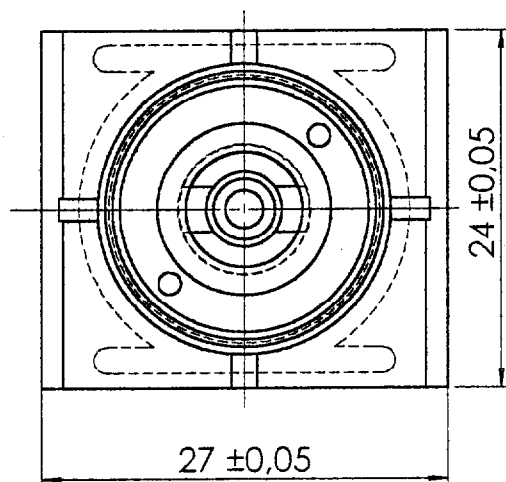
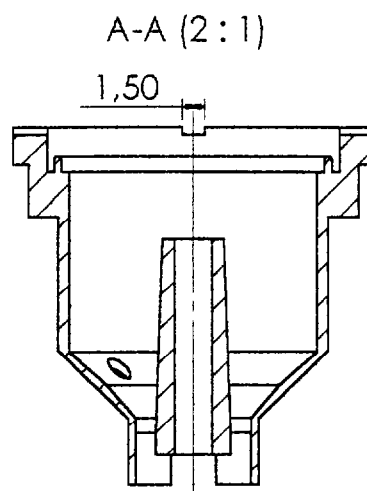
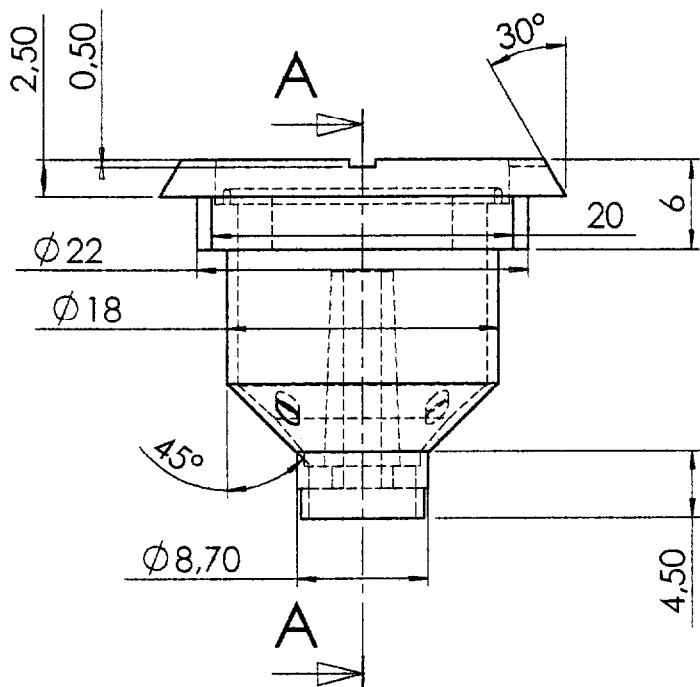

Tolérance générale: Js12

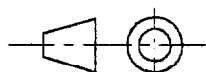

Bouchon

Echelle: 2:1

3 faces d'aspect

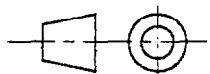
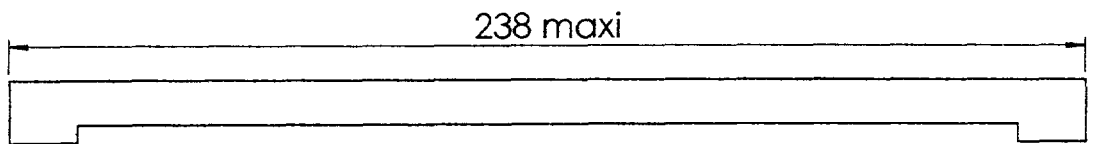
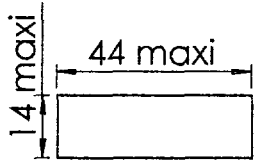
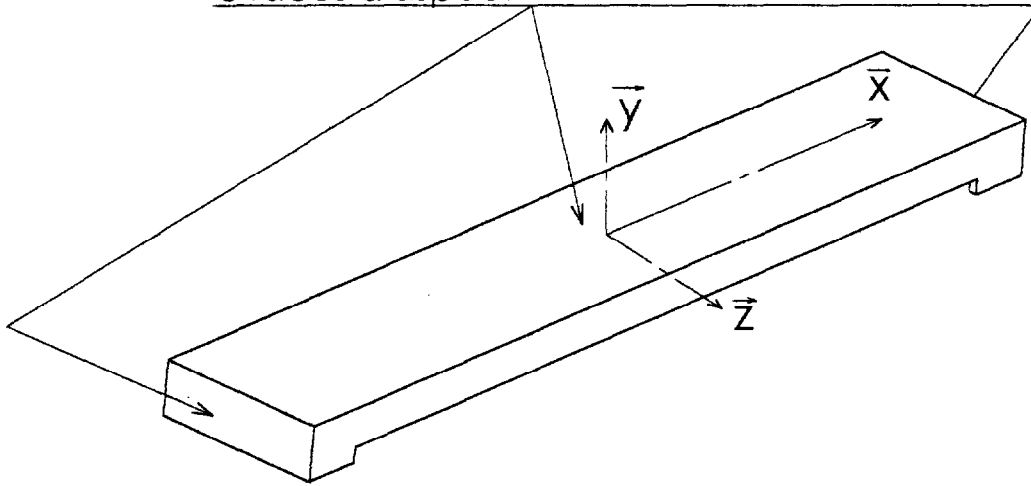

Capot de rampe - Ebauche

Echelle: 0,6:1

Variation du temps de solidification

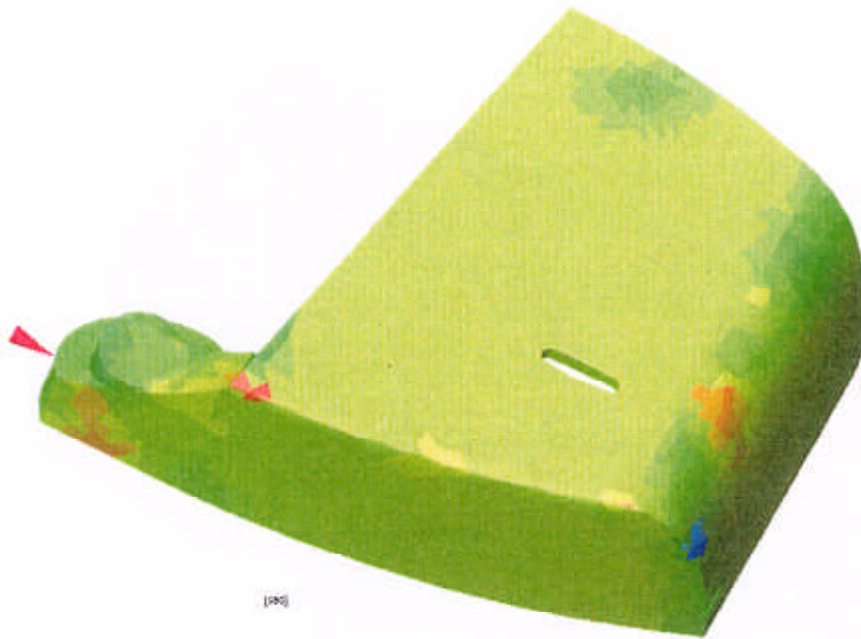

[s]

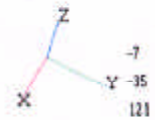

Variation du temps de solidification

[s]



20 mm

Variation du temps de solidification



[s]

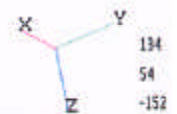
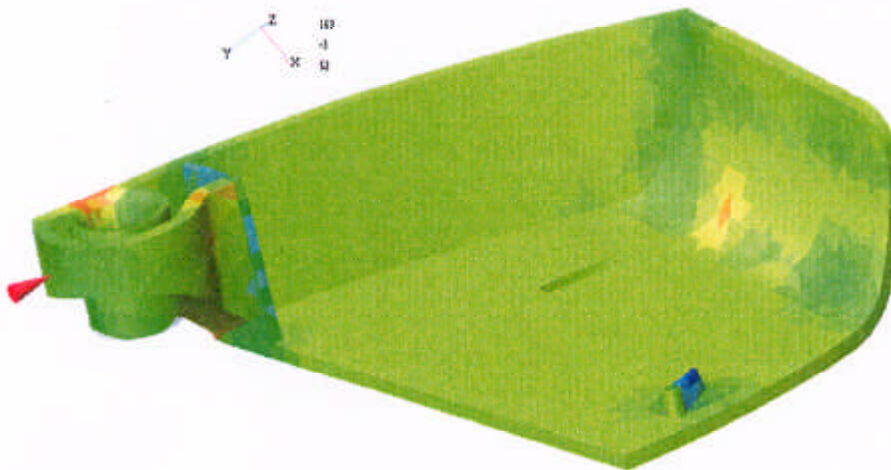

20 mm

Variations de température de surface

[deg c°]

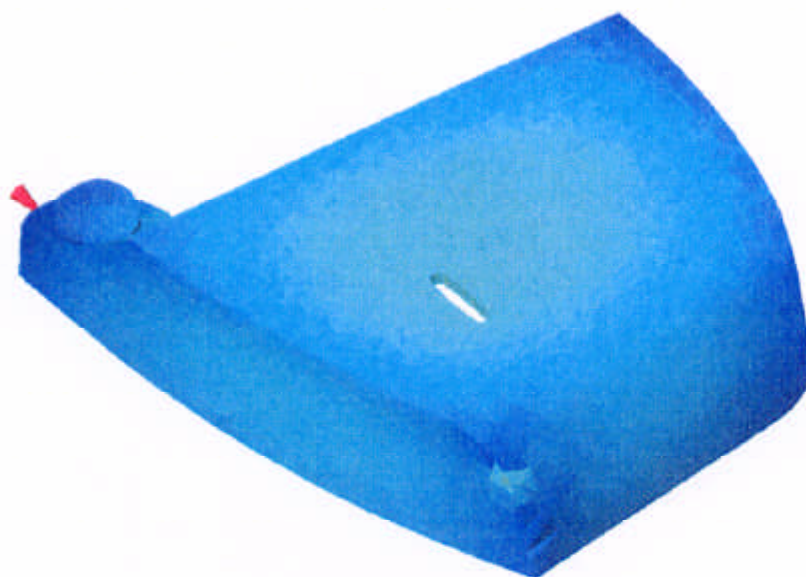

Moldflow

20 mm

Temp. de surface Variations

[deg.C]

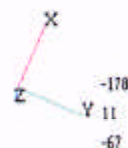
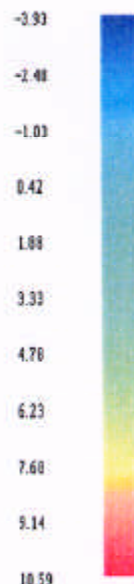

Moldflow

20 mm

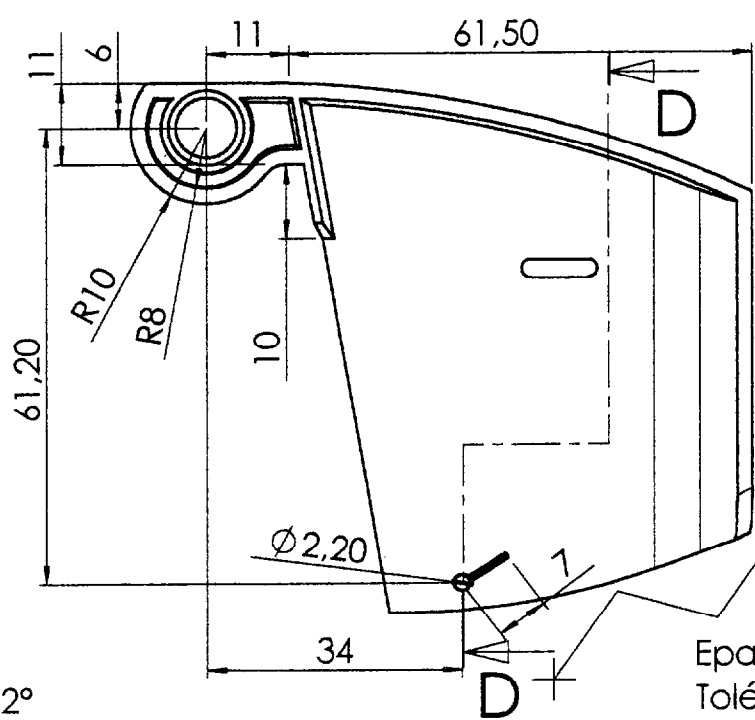
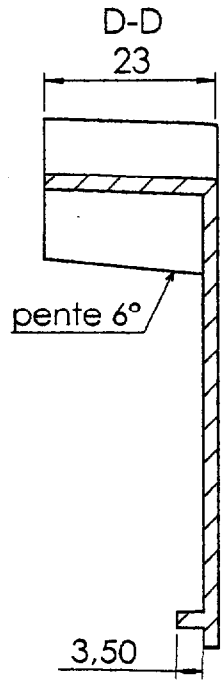
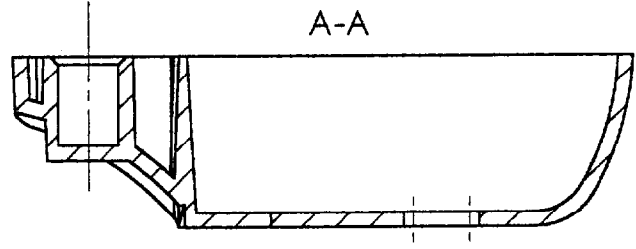
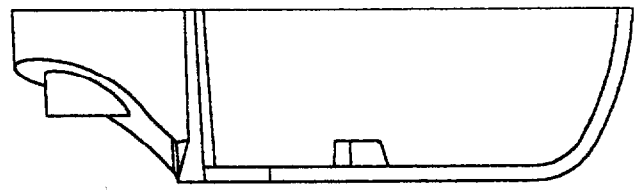
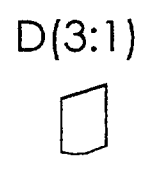
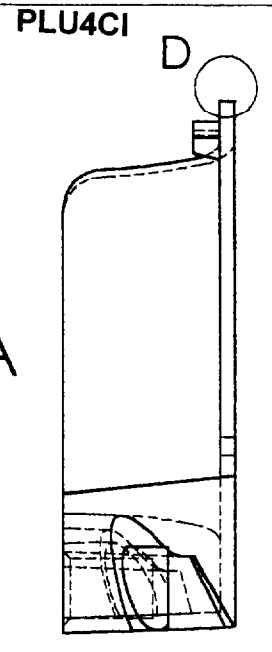
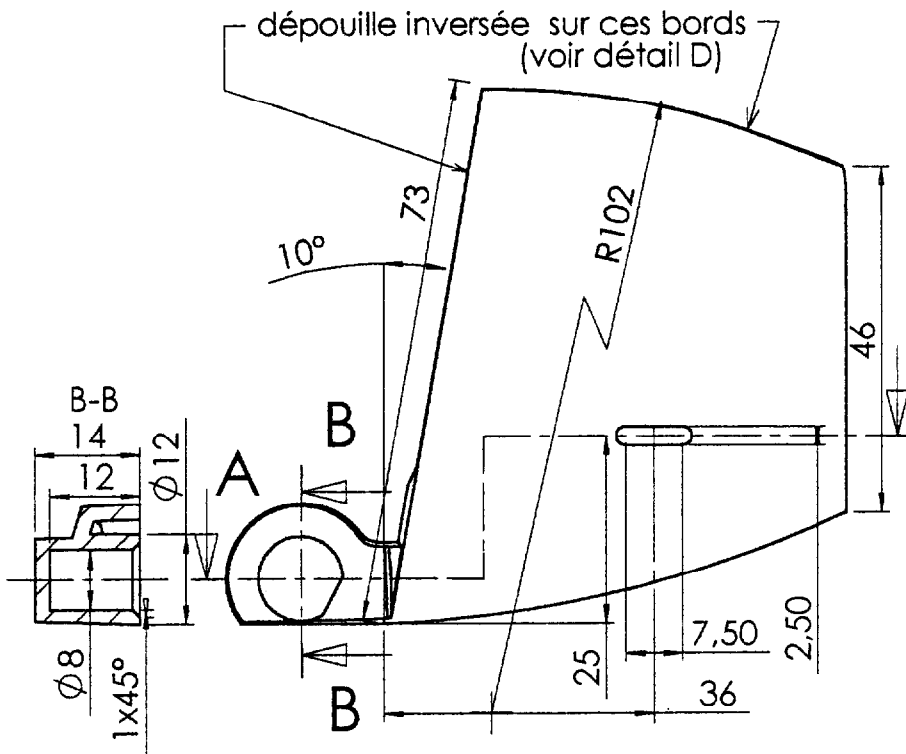
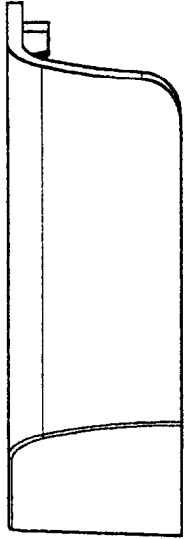

Epaisseur moyenne = 2 mm
Tolérance générale: Js 13

Dépouille générale 2°

Cache-borne -

Echelle 1:1