

H G F E D C B A

8  
7  
6  
5  
4  
3  
2  
1

8  
7  
6  
5  
4  
3  
2  
1

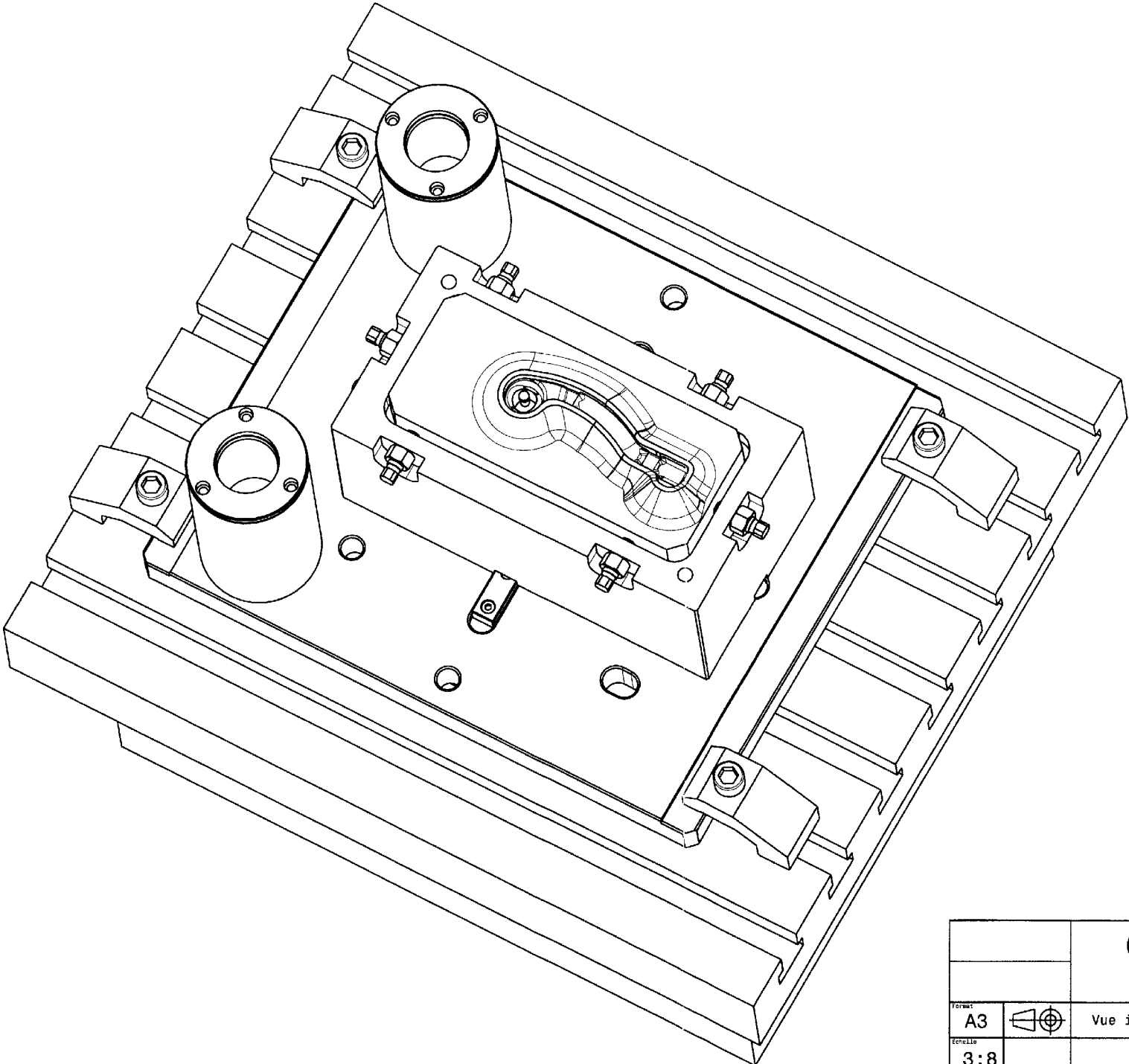

		<b>OUTIL REPRISE DE FORGE</b>		I	---	
				H	---	
				G	---	
				F	---	
				E	---	
				D	---	
Format			Vue isométrique outillage supérieur		C	---
A3					B	---
Echelle		Analyse d'outillage		Page	5/16	
3:8				A	---	

H G B A

AA

Butée fixe par rapport au bâti machine

Point mort haut H=690

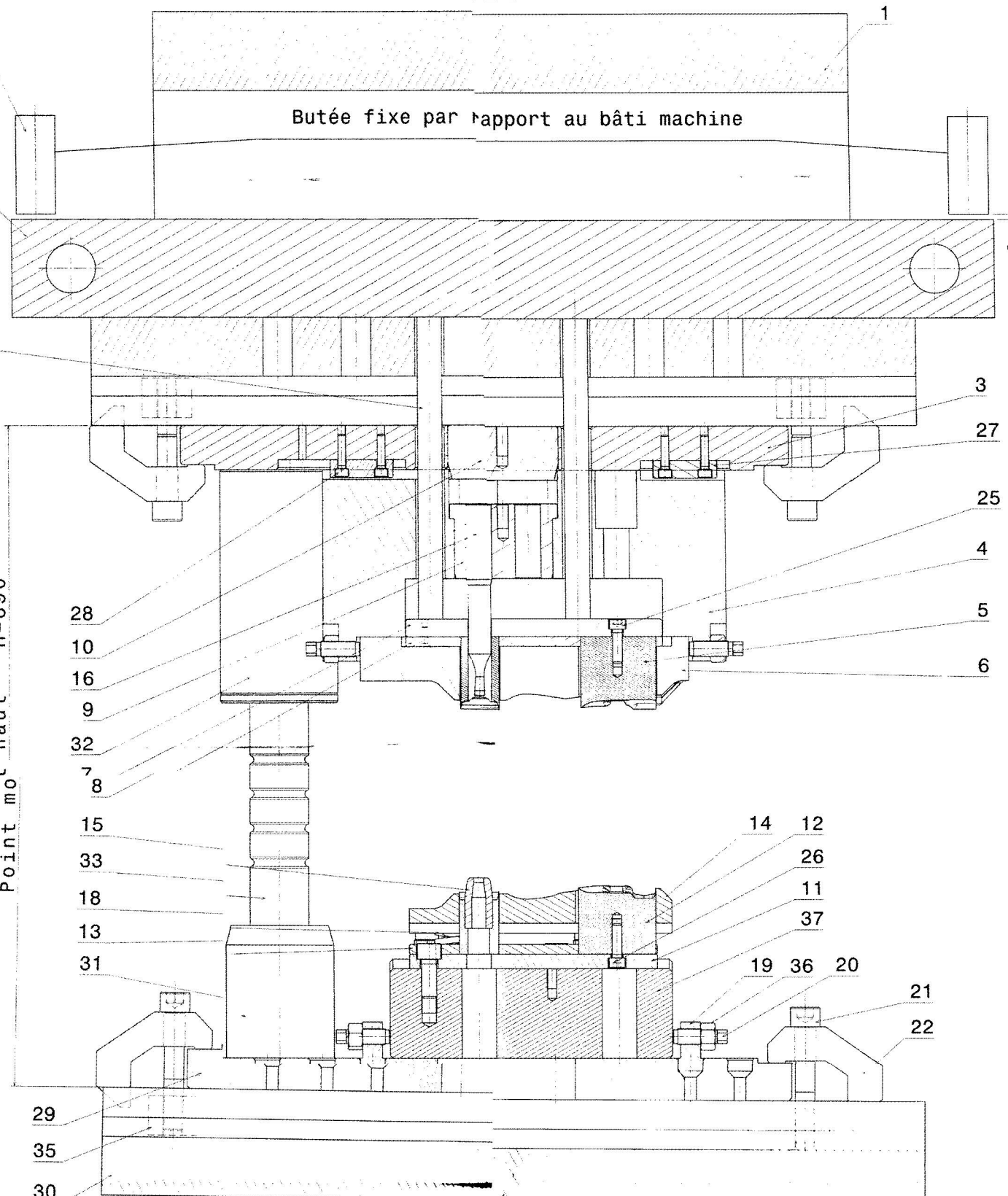

Vue isométrique ensemble 11,12,13 et 15  
Echelle 1:2

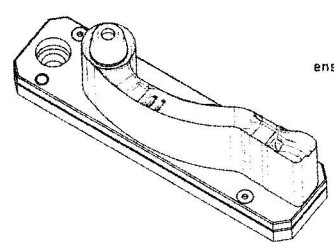

Vue de dessus  
Outillage inférieur  
Echelle 1:8

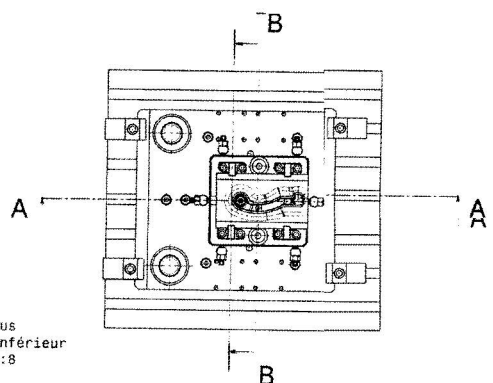

		<b>OUTIL REPRISSE DE FORGE</b>		1
				H
				G
				F
				E
				D
				C
				B
				A
SPR: A1		Plan d'ensemble outillage en coupe		
ÉCHELLE: 1:2		Analyse d'outillage		6/16