

ACADÉMIE DE POITIERS

SESSION JUIN 1999

BREVET D'ETUDES PROFESSIONNELLES

ELECTRONIQUE

LANGUE VIVANTE ANGLAIS

Durée : 1 h 30

L'usage du dictionnaire bilingue est autorisé.

Ce sujet comporte 3 pages

Recording on an MD

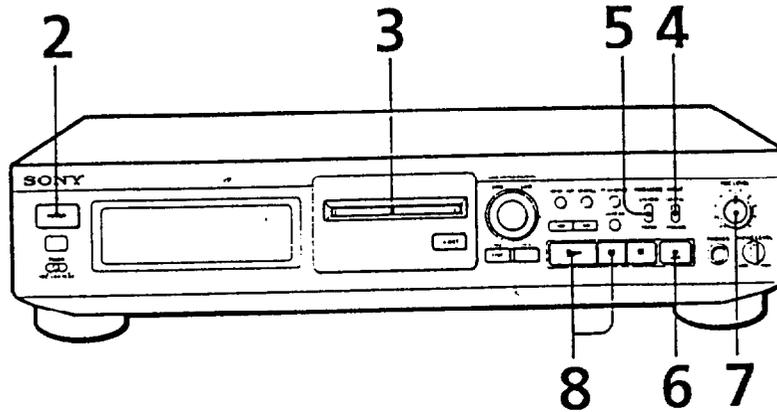

1. Turn on the amplifier and play the program source you want to record.
2. Press POWER
The POWER indicator changes from red to green.
3. Insert a recordable MD.

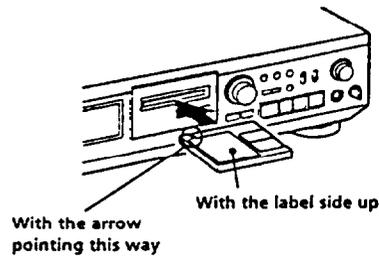

If the MD has a recorded material on it, the deck will automatically start recording from the end of the last recorded track.

4. Set INPUT to the corresponding input connector.

To record through	Set INPUT to
DIGITAL IN	DIGITAL
LINE (ANALOG) IN	ANALOG

5. Set REC MODE to the mode you want to record in.

To record in	Set REC MODE to
Stereo sound	STEREO
Monaural sound*	MONO

* In the monaural recording, you can record about two times longer than in the stereo recording.

6. Press ● REC
The deck becomes ready to record.
7. When recording the analog input signal, adjust the recording level with REC LEVEL.
The fourth dot is satisfactory for most purposes.
8. Press ▷ or || .
Recording starts.
9. Start playing the program source.

Do not disconnect the deck from the power source immediately after recording.

If you do, recorded material may not be saved to the MD. To save the material, after recording, press = EJECT to take out the MD or change the deck to standby by pressing POWER. "TOC" will flash in the display at this time. After "TOC" stops flashing and goes out, you can pull out the AC power cord.

To protect an MD against accidental erasure

To make it impossible to record on an MD, slide the tab in the direction of arrow, opening the slot. To allow recording, close the slot.

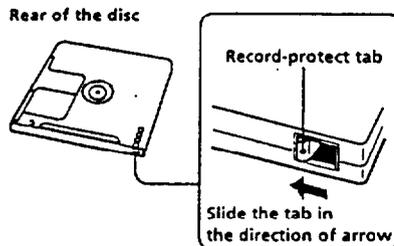

Note

If you switch REC MODE during recording or recording pause, recording stops.

TROUBLESHOOTING

If you experience any of the following difficulties while using the deck, use this troubleshooting guide to help you remedy the problem.

The deck does not operate or operates poorly.

The MD may be damaged ("Disc Error" appears). Take the MD out and insert it again. If "Disc Error" remains, replace the MD.

The deck does not play back.

→ Moisture has formed inside the deck. Take the MD out and leave the deck in a warm place for several hours until the moisture evaporates.

→ The deck is not on. Press POWER to turn the deck on.

→ The MD is inserted in the wrong direction. Slide the MD into the disc compartment with the label side up and the arrow pointing towards the opening until the deck grips it.

The deck does not record.

→ The MD is record-protected ("Protected" appears). Close the record-protect slot.

→ The deck is not connected properly to the sound source. Make connections properly to the sound source.

→ There is not enough time left on the MD. Replace it with another recordable MD with fewer recorded tracks, or erase unnecessary tracks.

→ There has been a power failure or the AC power cord has been disconnected during recording. Data recorded to that point may be lost. Repeat the recording procedure.



MDS-JE500

1996 by Sony Corporation

TRAVAIL A FAIRE PAR LE CANDIDAT

I - Lisez attentivement le guide dépannage.

Dans un compte rendu en français (120 mots environ), citez les raisons qui peuvent empêcher :

- la lecture du minidisque
- l'enregistrement du minidisque

Pour chacune de ces raisons, donnez les moyens d'y remédier.
(0,5 pt par raison donnée - 0,5 pt par remédiation proposée)

7 pts

II - Traduisez en français le passage intitulé Trouble shooting de "If you experience..." jusqu'à "... replace the MD".

6 pts

III - Répondez en anglais aux questions suivantes en faisant des phrases complètes.

7 pts

- 1 - What does MD stand for ?
- 2 - When does the power indicator change from red to green ?
- 3 - How must a recordable MD be inserted ?
- 4 - What's the REC LEVEL knob used for ?
- 5 - What can happen if you switch off just after recording ?
- 6 - Why can monaural recording be more interesting than stereo recording ?
- 7 - What is the consequence of opening the slot on the minidisc ?